

# **HOT SHOT**

## **TR1000**

### **IRRIGATION MANUAL**

*Pg.*

2	HOW IT WORKS & MOUNTING
3	INDICATOR LIGHTS
3	CODE SWITCH SETTINGS
4	TRANSMIT - TX FUNCTIONS
4	OPERATING THE TEST BEACON
5	BASIC PIVOT PANEL INSTALLATION & OPERATION
5	LAST PIVOT STANDING MODE & OPERATION
6	REINKE PIVOTS
7	T-L ELECTRIC PANEL
8	VALLEY 4000, 6000, AND PANELS WITH 3 SEC DELAY PCB.
9	VALLEY 8000, PRO PANEL, SELECT PANEL AND SIMILAR
10	ZIMMATIC PIVOT 10 WIRE SYSTEM
11	ZIMMATIC PIVOT 11 WIRE SYSTEM
12	ENGINE DRIVEN PIVOT AND T-L ENGINE PIVOT (ISUZU PANEL)
13	OUTPUT RELAY RX - FUNCTIONS
13	ENGINE STARTUP MODE
13	SUPERVISION FEATURE
13	FAILSAFE OPERATION
14	ENGINE PUMP WIRING & OPERATION
15	ELECTRICAL PUMP WIRING & OPERATION
16	PROPER GROUNDING
17	WARRANTY

**ATTENTION:** All Hot Shot units have a designated GROUND Terminal. Hot Shot units must have the ground terminal connected to a proper ground or grounding system as per the NEC (*National Electrical Code*) and or your local and state electrical code guidelines.

**ATTENTION:** Depending upon the style of system that your are going to control with the Hot Shot Wireless Controller you may need to supply additional parts. Such as relays, step-down transformers, Murphy switches etc. These items are suggested in the wiring guides that follow in this manual.

## HOW IT WORKS

The TR-1000 is a TRANSCEIVER. Transceivers can transmit and receive communications. This allows a TR-1000 to be installed at a pivot or at a pump. To simplify things in this irrigation manual we will call the TR-1000 that is installed at the pivot the TRANSMITTER (*a transmitter sends out commands. In this application it will send out pump on and off commands*) and the TR-1000 at the pump will be called a RECEIVER (*receivers, receive commands from the transmitter to activate or deactivate something. In this manual it will be used to turn on and off a pump*). The left side of the TR-1000's circuit board is the transmitter and the right side is the receiver.

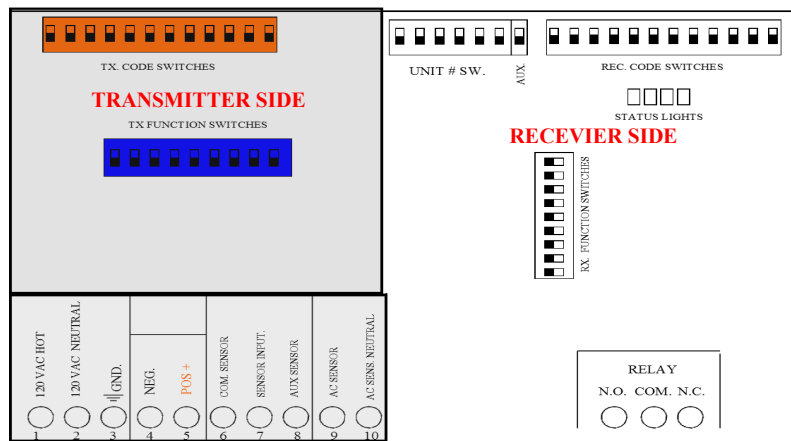

## BASIC OPERATION

Think of a Hot Shot control system as a wireless switch. When the transmitter's sensor is activated the relay output on a receiver will be activated and turn on a device such as pump, motor or a light. When the sensor is deactivated on the transmitter it will deactivate the relay on the receiver turning of the device it is connected to.

## MOUNTING

Cabinets are a weatherproof UV protected NEMA 4X cabinet with mounting ears on top and bottom. The Hot Shot control boxes can be mounted on the side of a control panel, pole or any other surface as long as the antenna does not have metal running within 12" of the antenna whip. If longer range is needed, an external long range antenna can be used. Do not mount the HOT SHOT to the well engine or cover because the strong vibrations can be harmful to the unit.

If installing these on a Variable Frequency Drive do not mount the Hot Shot unit to the VFD because of the potentially strong magnetic field interference that can be produced by these drives. The further away it is mounted the better it is for the Hot Shot's ability to transmit and receive.

## BATTERY BACKUP

During a power outage, a gel cell rechargeable battery supplies power to a Hot Shot for approximately 24 hours. This allows a pivots Hot Shot to send a shutdown signal to the pump when the pivot has lost power. The Hot Shot comes with a battery save feature that will turn off the Hot Shot if the voltage drops from 12vdc to 10vdc. This function will add years of life to the gel cell battery.

**Important...** When the battery has discharged, it will take approximately 2 to 3 hours for the battery to charge enough to operate the Hot Shot in case of another power failure. The battery should be replaced every year for the best reliability during power outages.

## INDICATOR LIGHTS

<b>POWER</b>	Signals that the Hot Shot has power and is ready operate.
<b>STROBE</b>	Used for troubleshooting, this LED flashes once for each of the four correct digits of the code received. The LED will stay on steady for one second if an incorrect digit of the code is received. <i>Example: If the LED flashes two times and then goes on steady it is indicating that the third digit doesn't match. If the LED flashes one time and goes on steady it is indicating that the second digit doesn't match. If the LED comes on steady right away it is indicating that the first digit doesn't match.</i>
<b>UNIT# STATUS 1 2 3 4</b>	When these LED's are on it indicates that its corresponding transmitter has activated the relay and the receiver is in Last Transmitter Standing Mode ( <i>Unit# switch and (Aux 7)</i> ) See description on pg 5.
<b>SUPERVISION</b>	When this LED is flashing it indicates that it has not received its correct code from the transmitter in the past 3hrs. Sliding function switch #8 to its OFF position will turn off this indicator light.
<b>TRANSMIT</b>	Indicates when the Hot Shot is transmitting.
<b>SENSOR</b>	When these LED's are on it indicates that the terminal below it is connected to the COMMON terminal.

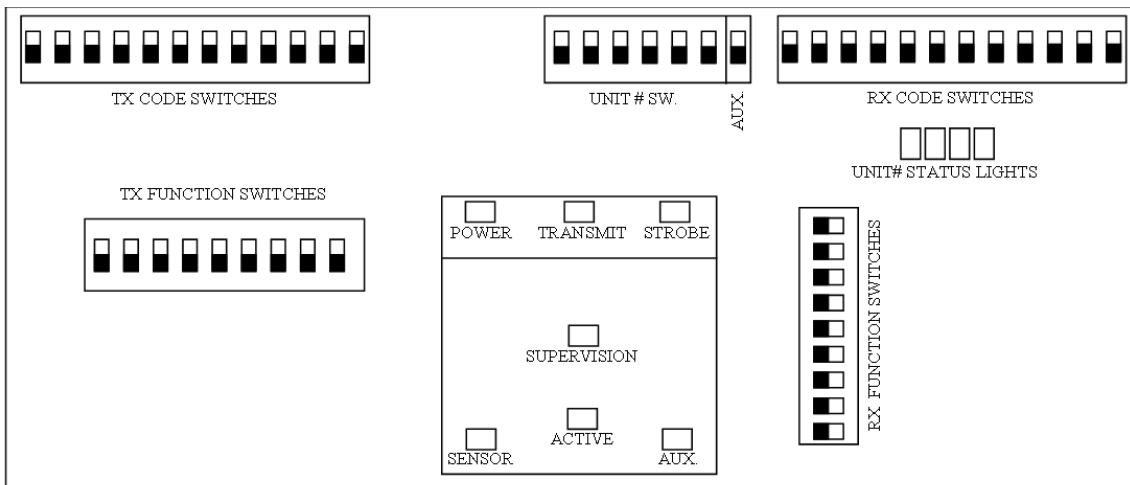

## CODE SWITCH SETTINGS

All Hot Shots are shipped from the factory with a preprogrammed 4 digit system code. This ensures that your neighbor will not duplicate the same system code as your units. Your Hot Shot's system codes should already match, so you do not need to program any codes. If a new secure system code is needed for your installation please call 785-623-1500 to be issued a secure system code for your area that the Hot Shots will be operating in.

If you ever need to replace a unit due to servicing, the field code can be programmed to match the existing or new add on units. FOLLOW THE EXAMPLE BELOW...

**EXAMPLE: CODE 6789**

**KEY**

3	4	5	6
7	8	9	0

Use the # KEY to the left to make each digit of the code. It takes three of the switches to make one number of the code.

Use switches 1,2,3 for the first # in the code. Switches 4,5,6 for the second #. Switches 7,8,9 for the third #. Switches 10,11,12 for the fourth #.

To watch a "How To" video on this feature click on the link below:

["CODE SWITCH SETTINGS"](#)

# TRANSMIT - TX FUNCTIONS

SWITCH#

3	ON	ACTIVATES TRANSPONDER OPERATION: <i>When ever a command is received, that same command will then be automatically retransmitted. Sensor inputs are disabled when in Transponder Operation.</i>
4	ON	MAKES IT A UNIT #2 TRANSMITTER
4&5 both	ON	MAKES IT A UNIT #3 TRANSMITTER
5	ON	MAKES IT A UNIT #4 TRANSMITTER
5&6 both	ON	MAKES IT A UNIT #5 TRANSMITTER
6	ON	MAKES IT A UNIT #6 TRANSMITTER
4,5,6 all	ON	DISABLES ALL TRANSMISSIONS ( <i>used when Hot Shot is receive only</i> ) <i>(For more details see Unit# - Function Switches 4,5,6 on pg 5.)</i>
8	ON	ACTIVATES THE TEST BEACON Used for testing and range finding only. When activated the Hot Shot will send a code every 10sec cycling a receiving Hot Shot's output relay. <b>To activate this feature put a jumper wire from the Input Sensor to COM terminal. DO NOT have the receiving Hot Shot wired to the pump during this test. This function must be turned off for normal operation. (For more details see <u>Operating The Test Beacon</u> below.)</b>
	OFF	NORMAL OPERATION MODE
9	ON	REFRESH (This function will retransmit the state of the Sensor Inputs once every 45 minutes.)
	OFF	NO REFRESH (Transmits the code only when there is a change of state on the Sensor Inputs.)

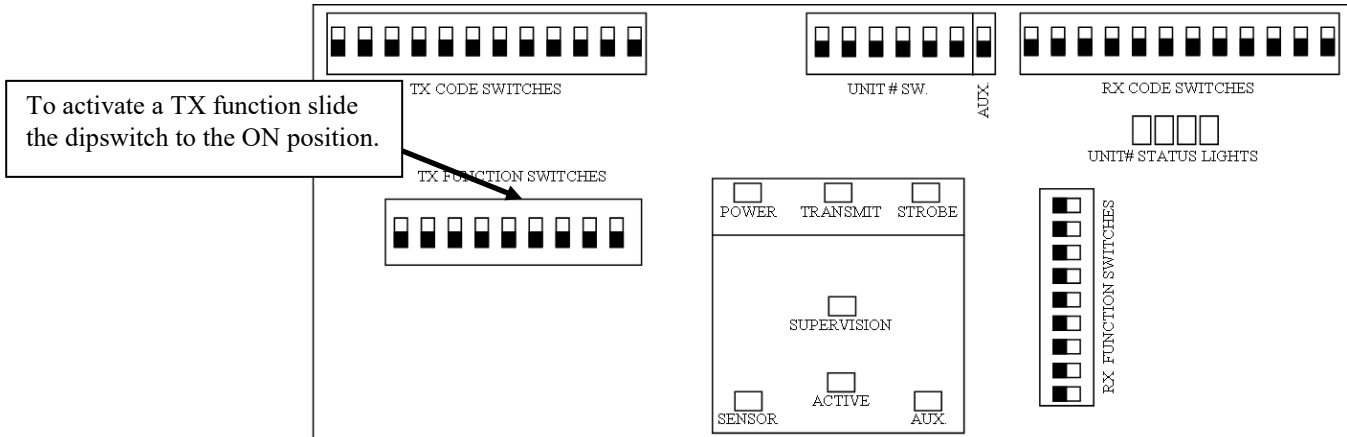

## OPERATING THE TEST BEACON

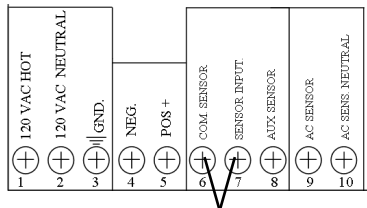

The Test Beacon function is turned on and off by using FUCNTION SWITCH #8 (see above). **This feature is used for testing and range finding purposes only.** To activate the Test Beacon first turn OFF the power to the Hot Shot. Turn function switch #8 on and connect a small jumper wire from the **SENSOR INPUT** terminal to the **COM** terminal and then turn the power back ON. *See diagram.* When turned ON the Transmitting LED will blink and the code will be transmitted every 10 seconds cycling a receiving Hot Shot's relay. **DO NOT have the receiving Hot Shot wired up to the pump** during this procedure be-

cause it will continually open the relay for 10 seconds and then close the relay for 10 seconds causing damage to the pump.

**Function switch #8 must be turned OFF, the jumper wire removed and then turn off the power of the Hot Shot to take it out of Beacon Mode.**

To watch a "How To" video on this feature click on the link below:

["OPERATING THE TEST BEACON"](#)

## **TRANSMIT# - FUNCTION SWITCHES(4,5,6)**

Using unit #'s on the Hot Shot can create a more precision controlled system. When needing to use multiple transmitters that control a single receiver, assigning unit #'s to each transmitter on the system will help the receiver to differentiate between the transmitters controlling it. This operation is often referred to as a Last Pivot Standing scenario. All Hot Shots come from the factory set in the default mode as a #1 transmitter. Meaning they will only control the relay output #1 on a 810-R Plus receiver, a receiver set as a Unit #1 receiver or channel 1 of a receiver operating in Last Pivot Standing mode. Turning on function switch #4 will make a transmitter a Unit #2 transmitter that will control the relay output #2 on a 810-R Plus receiver, a receiver set as a Unit #2 receiver or channel 2 of a receiver operating in Last Pivot Standing mode. The results are the same for each corresponding Unit # that a transmitter is set to.

## **UNIT# SWITCHES(1,2,3,4,5,6,) AND (AUX #7)**

When a Hot Shot (810-R or TR1000) is going to be used with A Hot Shot (810-T or TR1000) transmitter using it's #1,2,3,4,5 and 6 SENSOR control, the Hot Shot going to be controlled will need to be assigned to the sensor on the transmitter that will control it. All Hot Shots come factory set in the default mode as a UNIT #1. Meaning they are only controlled by a Hot Shot that is transmitting as a Unit #1. When using the SENSOR INPUT #2 or higher on a transmitter you will need to use the **UNIT# DIP SWITCHES** located to the left of the 12-digit RX CODE SWITCHES to program the Hot Shot so it can be controlled by it's corresponding transmitter. You can make it a #2 receiver (*which is controlled by a #2 transmitter*) by only turning on the #2 dipswitch. *See picture.* You can make it a #3 receiver (*which is controlled by a #3 transmitter*) by only turning on the #3 dipswitch. This makes it capable for the pivot to control and share multiple wells. Also see Multi Pivot Operation in the transmitter section.

### **Last Pivot Standing Mode & Operation (Unit# switches and (Aux 7))**

This mode is used when 2 or more (*up to 6*) different pivots are sharing the same pump and the pump can stay running until all the pivots are done and have transmitted the relay OFF command. Each UNIT# STATUS LED on the pumps' Hot Shot will light up when its corresponding pivot's Hot Shot has sent the relay ON command. When a pivots' Hot Shot sends its relay OFF command to the pump's Hot Shot the corresponding UNIT# LED will turn off. For the pump to include each pivot in the control sequence the corresponding UNIT# switch on the pumps' Hot Shot must be turned on for each pivot that is controlling it.

**NOTE** - all pivots that transmitted in a relay ON command must transmit the relay OFF command or the pump will never stop.

*To watch a "How To" video on this feature click on the link below:*

["LAST PIVOT STANDING MODE"](#)

## **BASIC PIVOT PANEL INSTALLATION AND OPERATION**

Most pivot installations will use this basic method because they only have a single throw pump control relay in their panel. (*Single throw relays only have a COMMON and NORMALLY OPEN contact.*) The pivots well control relay will be connected to the **ON-OFF INPUT** and the **COM** terminal on the pivot's Hot Shot. When there is contact made between **SENSOR INPUT** and **COM** (*when requesting water*) the Hot Shot will send out the ON code to the pump's Hot Shot activating it's relay and starting the pump. When contact is opened between **SENSOR INPUT** and **COM** (*such as when the pivot is finished or stop water*) the pivot's Hot Shot will send out the OFF code to the pump's Hot Shot de-activating it's relay and stopping the pump. Brand specific wiring instructions are shown later in this manual.

*To watch a video on this click on the link below:*

["BASIC PIVOT PUMP CONTROL"](#)

# REINKE PIVOT

## WIRING INSTRUCTIONS FOR BASIC OPERATION

Typically all functions switches are off unless advanced features are needed. See function switch setting on page 3 for details.

**Attention: THE BACKUP BATTERY MUST BE INSTALLED FOR TRANSMITTER OPERATION.**

To supply the 120vac needed for the Hot Shot TR1000 to operate, run a wire from the pivot panel's J13 terminal to the #1 terminal (120vac Hot Terminal). Run another wire from the pivot panel's neutral terminal J9 to the #2 terminal (120vac Neutral Terminal). Connect a wire from the Lighting Ground terminal of the Hot Shot to an NEC approved ground rod. If your pivot panel has **NO** voltage on the pump control terminals then use the DRY CONTACT WELL KILL WIRING option below. If your pivot panel has AC voltage on the pump control terminals then use the 120VAC or 24VAC WELL KILL WIRING option below.

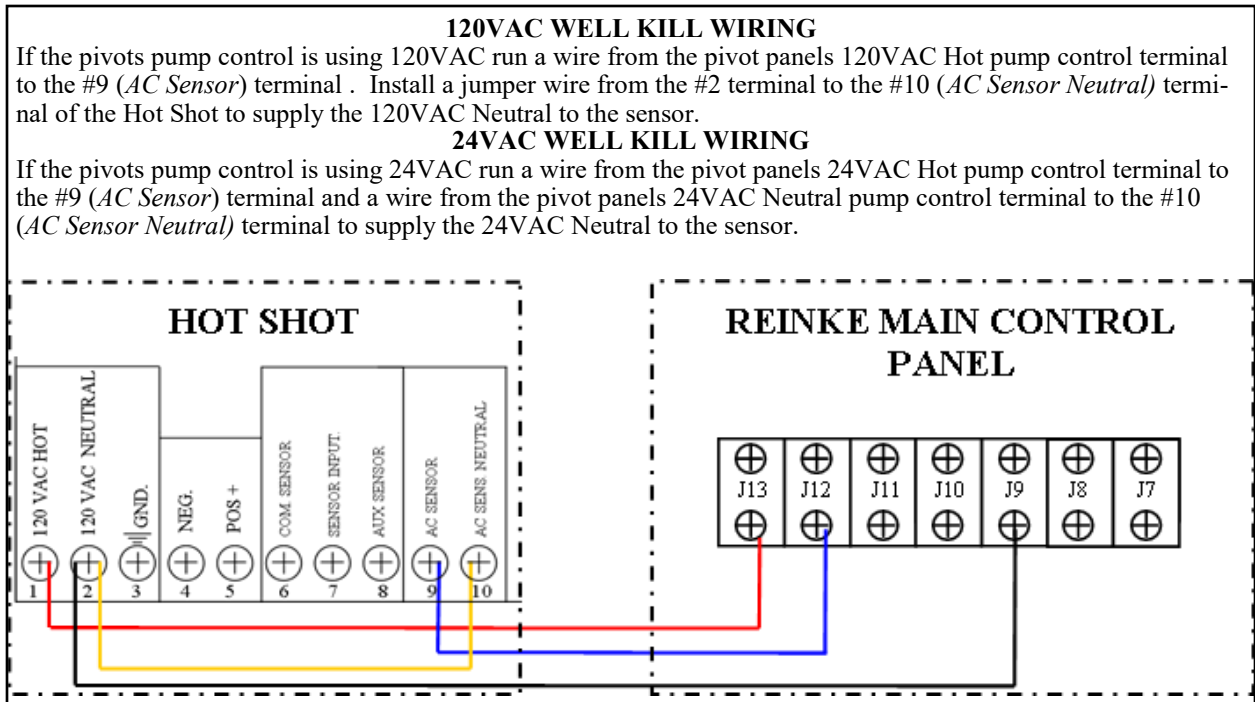
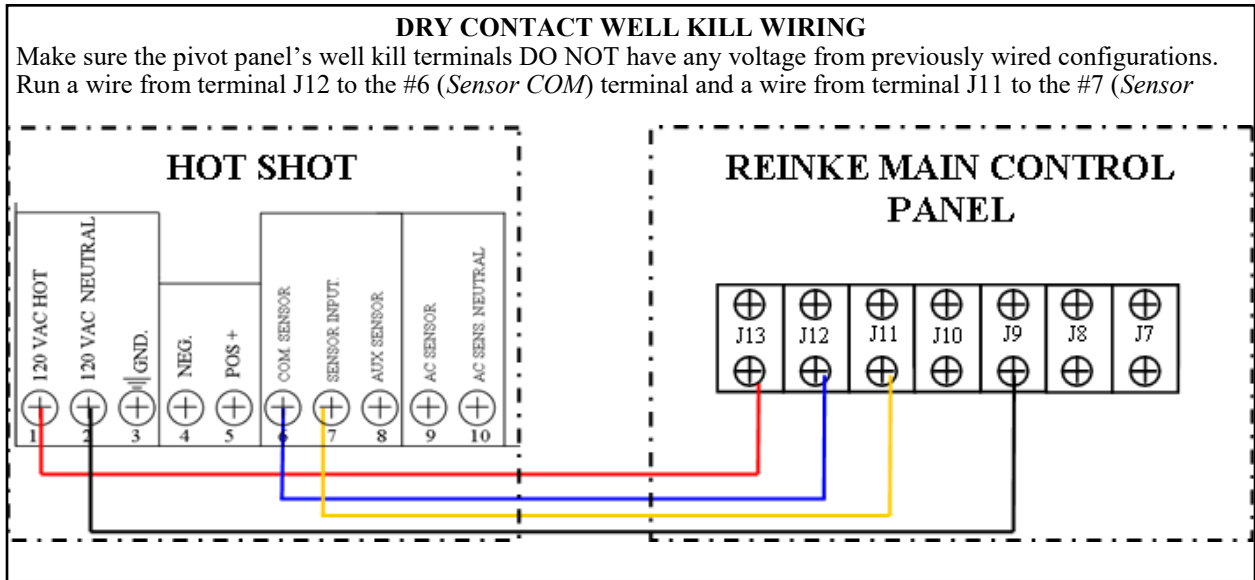

# T-L ELECTRIC PANEL (ALLEN BRADLEY)

## WIRING INSTRUCTIONS FOR BASIC OPERATION

*Typically all functions switches are off unless advanced features are needed. See function switch setting on page 3 for details.*

**Attention:** *THE BACKUP BATTERY MUST BE INSTALLED FOR TRANSMITTER OPERATION.*

**Attention:** *This install requires a 24vac to 120vac transformer.*

To supply the 120vac needed for the Hot Shot Transmitter to operate, install a 24VAC to 120VAC step up transformer. These are available to purchase from Hot Shot Systems. Run two wires from the 24 VAC input on the transformer to terminal #9 and #11 in the T-L Allen Bradley Panel. Then take the 2 wires from the 120VAC output side and connect them to terminals #1 (120vac Hot Terminal) and #2 (120vac Neutral Terminal) of the Hot Shot. Connect a wire from the Lighting Ground terminal of the Hot Shot to an NEC approved ground rod.

For pump control run a wire from the Allen Bradley panels #1 terminal to the #9 (AC Sensor) terminal and another wire from the Allen Bradley panels #2 terminal to the #10 (AC Sensor Neutral) terminal of the Hot Shot.

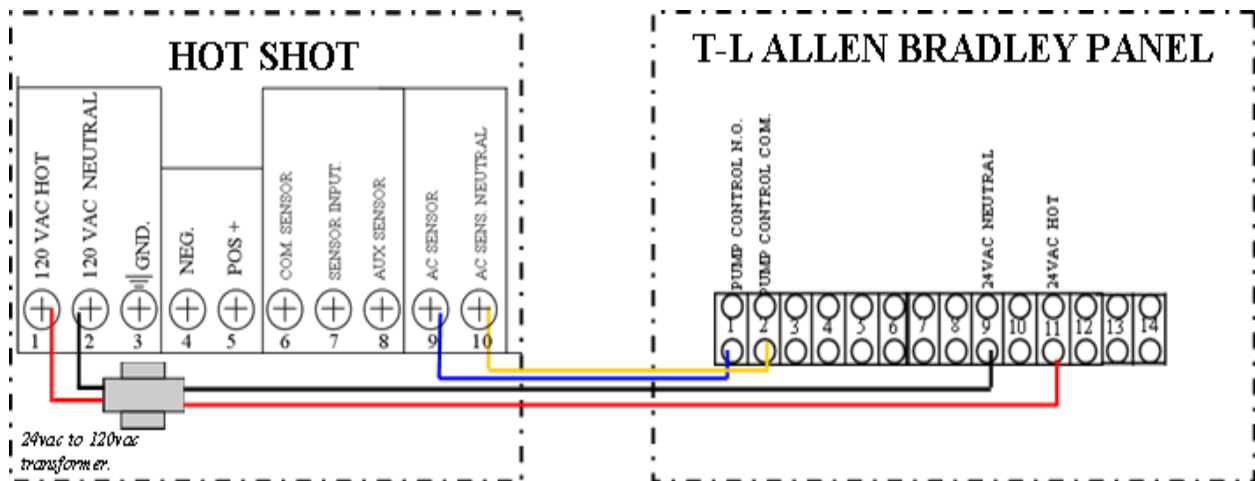

# VALLEY MODELS 4000, 6000, & PANELS WITH 3 SEC DELAY PCB.

## WIRING INSTRUCTIONS FOR BASIC OPERATION

*Typically all functions switches are off unless advanced features are needed. See function switch setting on page 3 for details.*

**Attention: THE BACKUP BATTERY MUST BE INSTALLED FOR TRANSMITTER OPERATION.**

To supply the 120vac needed for the Hot Shot TR1000 to operate, run a wire from the pivot panel's 120vac hot terminal on the fuse block to the #1 (120vac Hot Terminal) terminal and another wire from the pivot panel's neutral terminal to the #2 (120vac Neutral Terminal) terminal. Connect a wire from the Lighting Ground terminal of the Hot Shot to an NEC approved ground rod. If your pivot panel has **NO** voltage on the pump control terminals then use the DRY CONTACT WELL KILL WIRING option below. If your pivot panel has AC voltage on the pump control terminals then use the 120VAC WELL KILL WIRING option below.

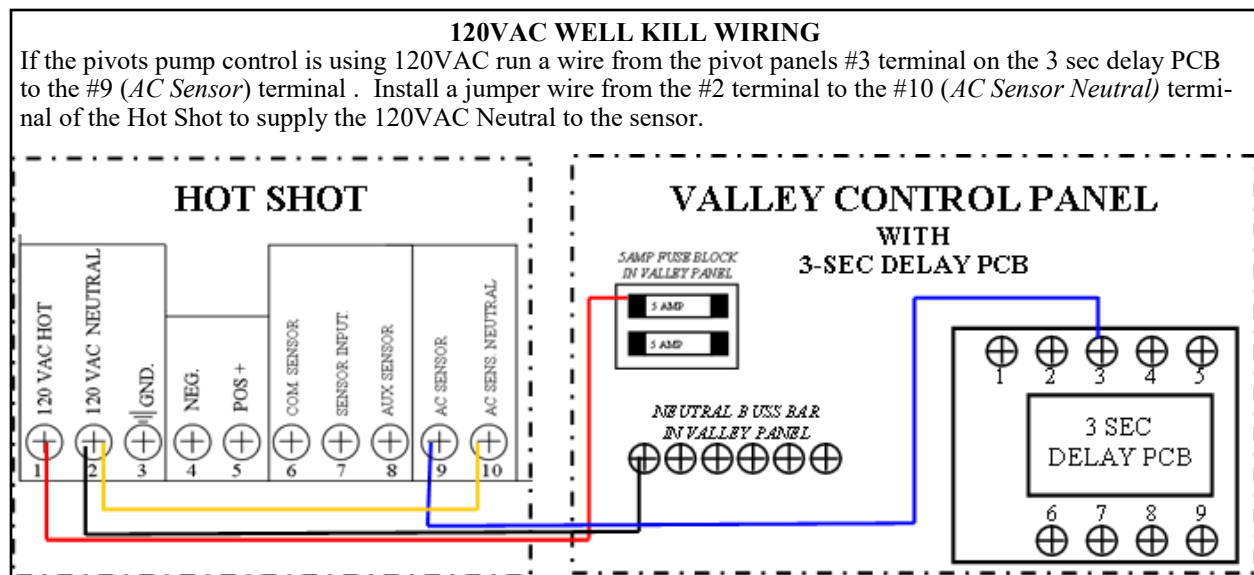
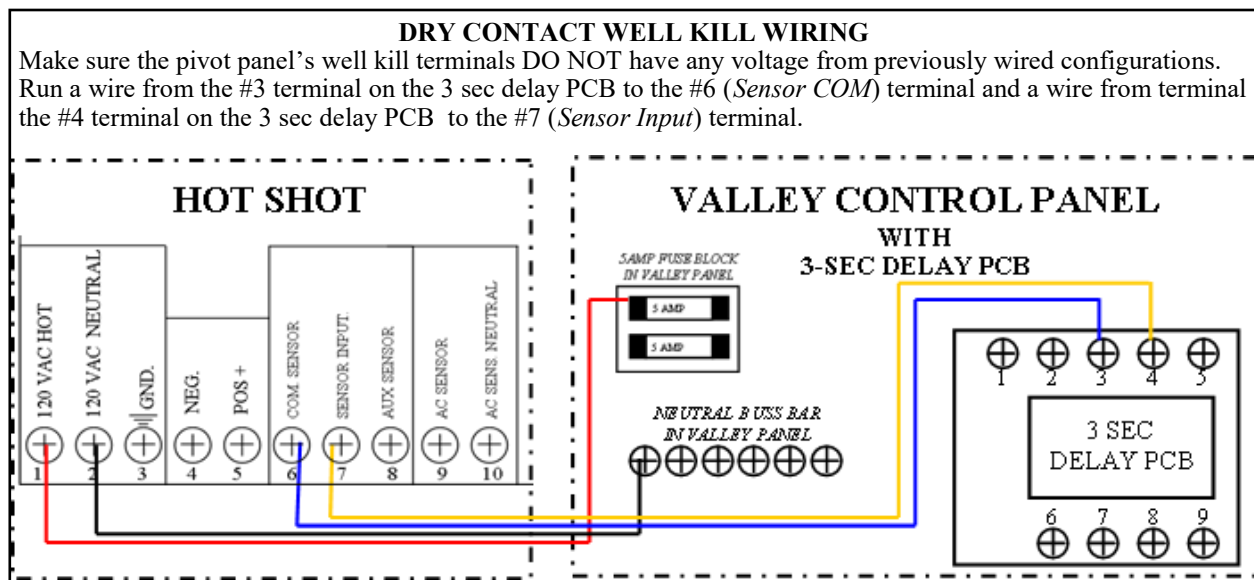



# VALLEY MODELS 8000, PRO PANEL, SELECT PANEL & SIMILAR

## WIRING INSTRUCTIONS FOR BASIC OPERATION

*Typically all functions switches are off unless advanced features are needed. See function switch setting on page 3 for details.*

**Attention: THE BACKUP BATTERY MUST BE INSTALLED FOR TRANSMITTER OPERATION.**

To supply the 120vac needed for the Hot Shot TR1000 to operate, run a wire from the pivot panel's 120vac hot terminal #3 to the #1 (*120vac Hot Terminal*) terminal and another wire from the pivot panel's neutral terminal #10 to the #2 (*120vac Neutral Terminal*) terminal. Connect a wire from the Lighting Ground terminal of the Hot Shot to an NEC approved ground rod. If your pivot panel has **NO** voltage on the pump control terminals then use the DRY CONTACT WELL KILL WIRING option below. If your pivot panel has AC voltage on the pump control terminals then use the 120VAC WELL KILL WIRING option below.

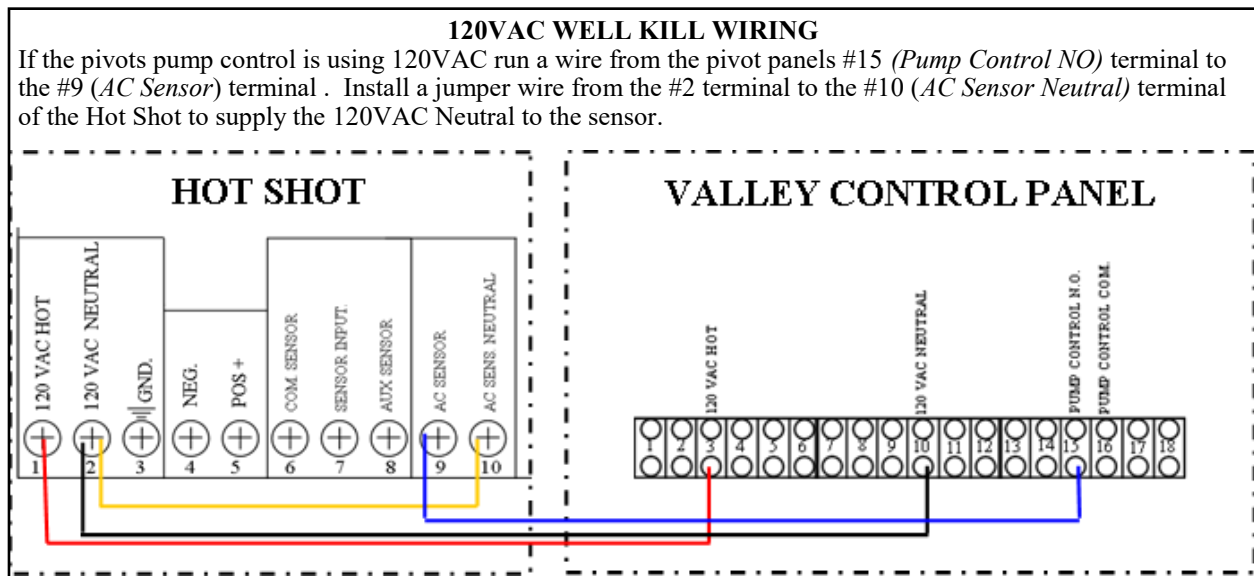
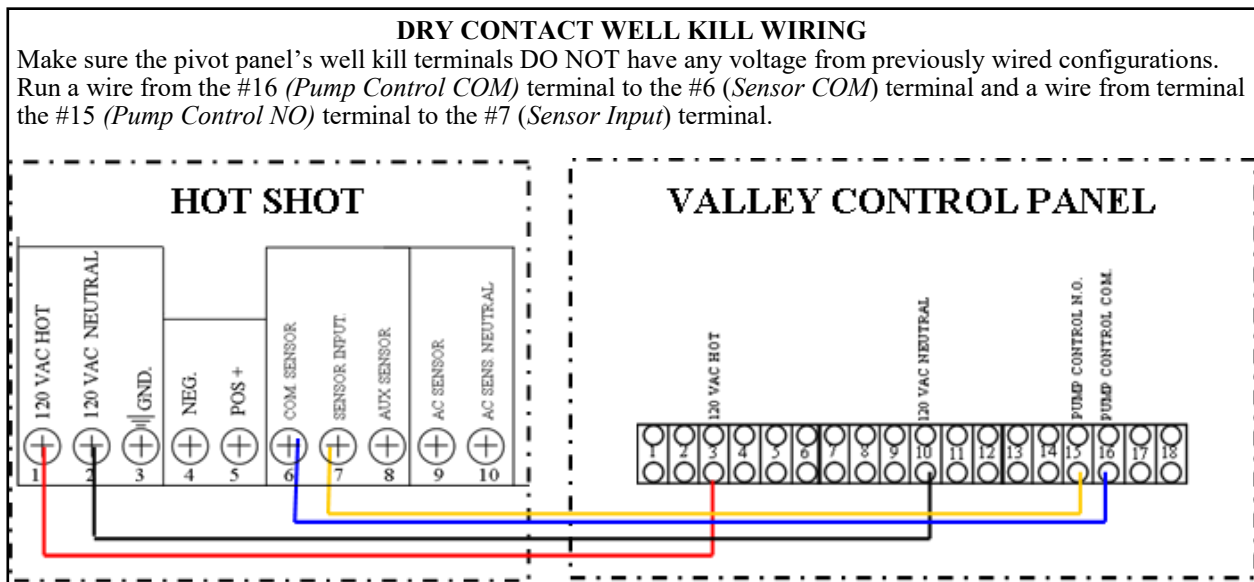

# ZIMMATIC PIVOT 10 WIRE SYSTEM

## WIRING INSTRUCTIONS FOR BASIC OPERATION

Typically all functions switches are off unless advanced features are needed. See function switch setting on page 3 for details.

**Attention: THE BACKUP BATTERY MUST BE INSTALLED FOR TRANSMITTER OPERATION.**

To supply the 120v needed for the Hot Shot to operate run a wire from the pivot panels 120v X1 terminal to the #1 (120vac Hot) terminal and another wire from the 120v X2 terminal to the #2 (120vac Neutral) terminal on the Hot Shot. For pump control, run a wire from the Zimmatic's #64 terminal to the #9 (AC Sensor) terminal and another wire from the Zimmatic's #4 terminal to the #10 (AC Sensor Neutral) of the Hot Shot. Connect a wire from the Lighting Ground terminal of the Hot Shot to an NEC approved ground rod. See diagram below.

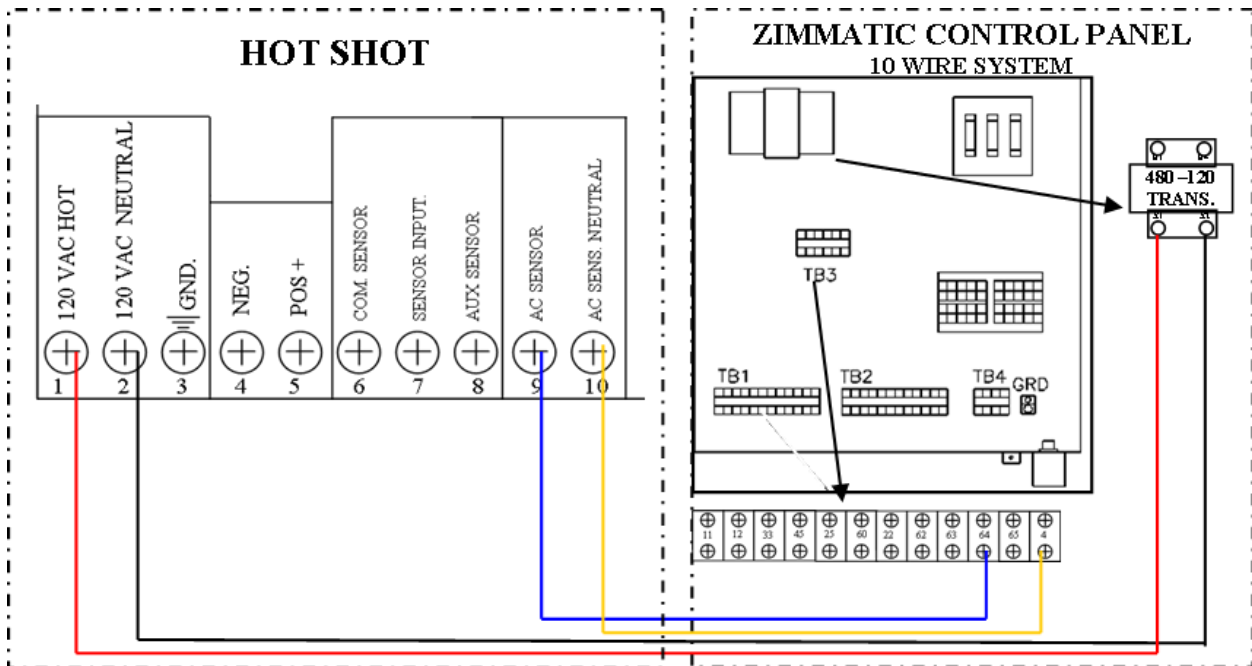

# ZIMMATIC PIVOT 11 WIRE SYSTEM

## WIRING INSTRUCTIONS FOR BASIC OPERATION

Typically all functions switches are off unless advanced features are needed. See function switch setting on page 3 for details.

**Attention: THE BACKUP BATTERY MUST BE INSTALLED FOR TRANSMITTER OPERATION.**

To supply the 120v needed for the Hot Shot to operate run a wire from the pivot panels 120v X1 terminal to the #1 (120vac Hot) terminal and another wire from the 120v X2 terminal to the #2 (120vac Neutral) terminal on the Hot Shot. For pump control, run a wire from the Zimmatic's #64 terminal to the #9 (AC Sensor) terminal and another wire from the Zimmatic's #65 terminal to the #10 (AC Sensor Neutral) of the Hot Shot. Connect a wire from the Lighting Ground terminal of the Hot Shot to an NEC approved ground rod. See diagram below.

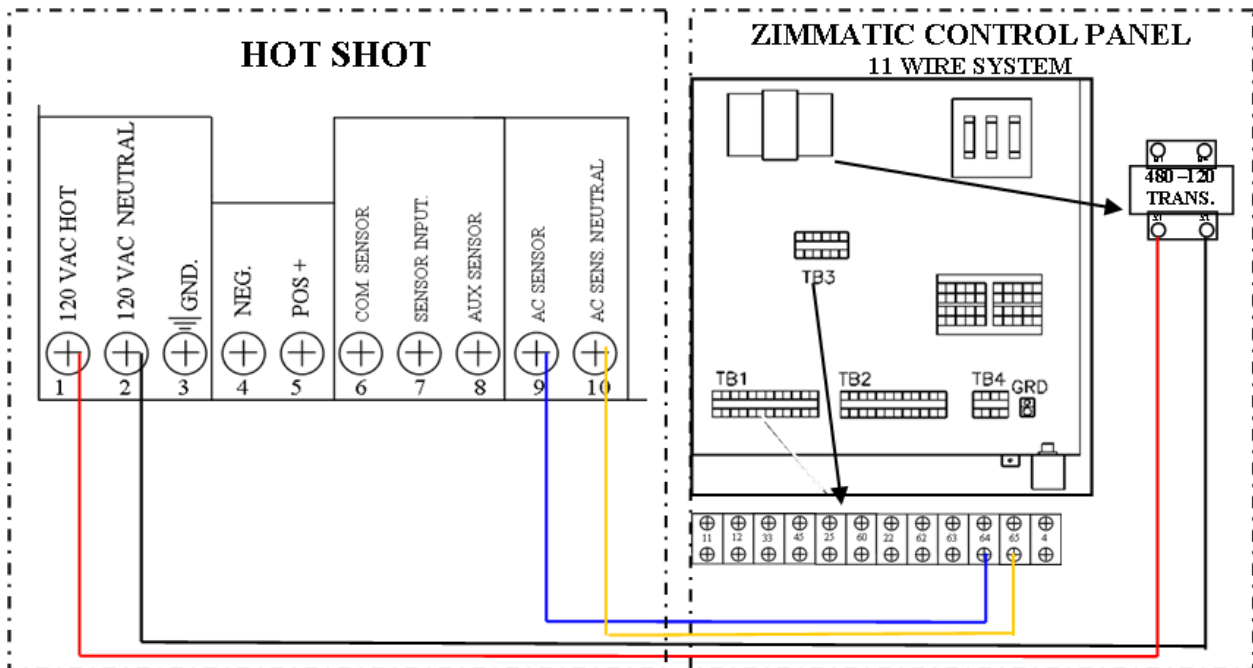

# ENGINE DRIVEN PIVOTS

## WIRING INSTRUCTIONS FOR BASIC OPERATION

*Typically all functions switches are off unless advanced features are needed. See function switch setting on page 3 for details.*

Run a wire from the B terminal on the engines Murphy switch to the #5 (+12vdc) terminal and a wire from the ground on the Murphy or from the NEG of the engines battery to the #4 (-12vdc) terminal on the Hot Shot. For pump control run a wire from the engines Murphy switch terminal C on a 117 or from the terminal NC on a 518 to the #7 (Sensor Input) terminal. Connect a wire from the Lighting Ground terminal of the Hot Shot to the ground lug of the panel. See diagrams below.

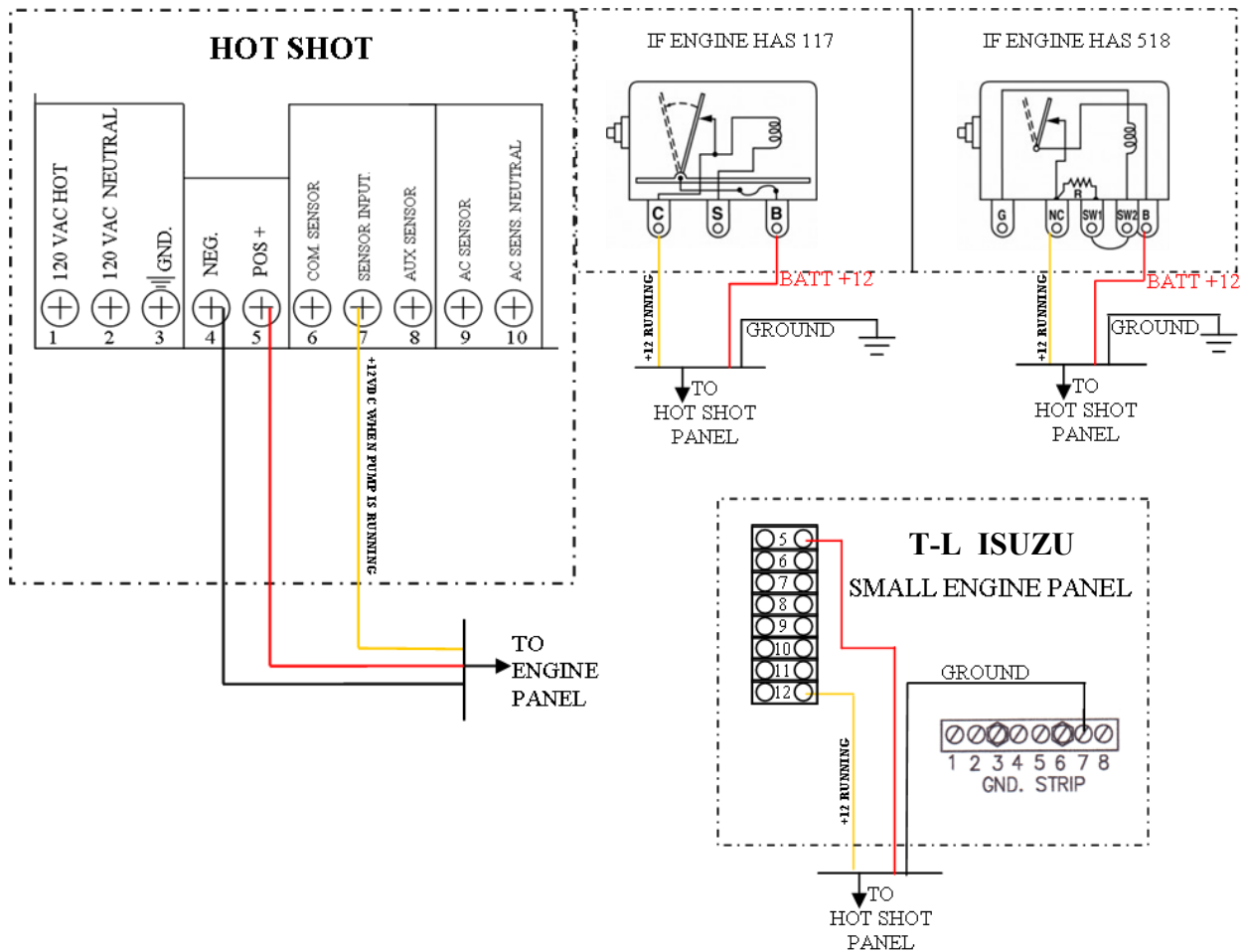

## OUTPUT RELAY - RX FUNCTIONS

### SWITCH#

1	ON	WILL ACTIVATE MOMENTARY FOR 10 SEC.
2	ON	INVERTED RELAY OUTPUT CONTROL
3	ON	ACTIVATION OF RELAY DELAYED BY 10 SEC. (See Load Sharing below)
4	ON	TESTS FAIL-SAFE OPERATION. (function 7 or 9 must be turned on)
5	ON	ACTIVATES THE OFF DELAY (50sec delay after the off command)
6	ON	ACTIVATES ENIGNE STARTUP MODE - WITH 15MIN BY-PASS TIMER (See below)
7	ON	ACTIVATES FAIL-SAFE MODE - SCENERIO 1 (See FAIL-SAFE OPERTAION below)
8	ON	ACTIVATES THE SUPERVISION MODE - LED ONLY.
9	ON	ACTIVATES FAIL-SAFE MODE - SCENERIO 2 (See FAIL-SAFE OPERTAION below)

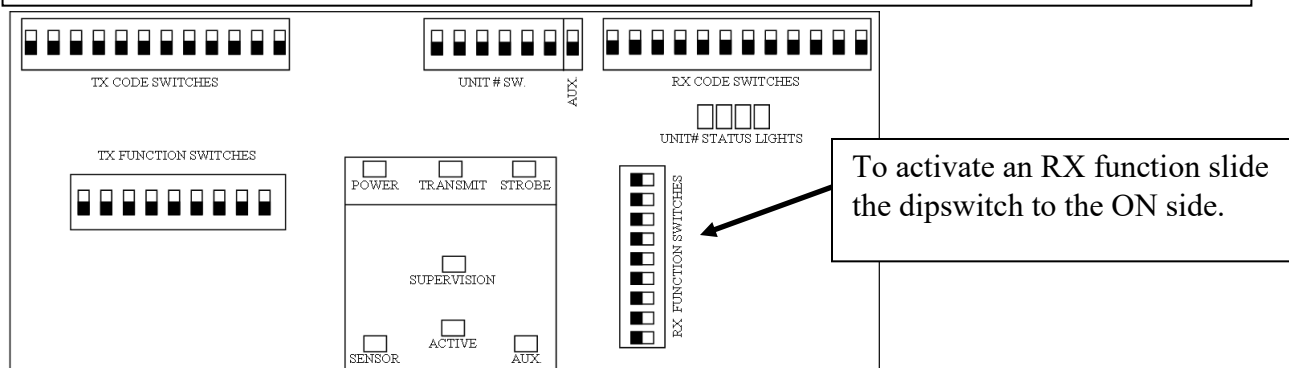

### OFF DELAY

Turning RX function switch 5 ON will put the receiver in OFF DELAY mode. This mode is most often used with a Roto-Phase converter or generator. When the Hot Shot receives an off command the deactivation of the relay will be delayed by 50 seconds allowing the Roto-Phase convertor or the generator the extra time needed to allow everything to shutdown.

### ENGINE STARTUP MODE

Turn RX function switch 6 ON and then turn on the power to the Hot Shot to enable the Engine Startup Mode. The Supervision LED will light up and the relay will come on to bypass the Murphy switch and allow the engine to start and stay running until the Hot Shot has received its relay ON command thus ending the bypass timer and taking control and turning off the Supervision LED. If the Hot Shot does not receive the relay ON command within 15 min the Hot Shot will kill the engine and you will have to turn the Hot Shot off and then back on again to get it into Engine Startup Mode again.

### SUPERVISION FEATURE

The Supervision Feature is a great way for checking at a glance the integrity of communications between Hot Shots. The supervision feature is designed to work with only one transmitter per system as the supervision feature's timer can operate on multiple receivers at the same time. When TX function 9 (Refresh) is turned on, it will send out a check-in signal (*technically it's a command telling each receiver on the system to reset it's supervision timer, i.e. system is working properly*) every 45 minutes. If the check-in signal is not heard by a Hot Shot before the internal supervision timer expires, due to transmit or receive issues, the Hot Shot will then look at its RX function switches (7, 8 or 9) and take the selected course of supervision or fail-safe action. See below.

### FAIL-SAFE OPERATION

This feature works with the Supervision feature as described above but lets us take safety a step further. Fail-Safe Operation allows the Hot Shot to control it's out put relay by activating or deactivating itself if any Hot Shot in the system is not working properly.

#### SCENARIO 1

**Turning on RX Function switch 7** will make the output relay energize if there is a system failure (closing N.O. to COM.).

#### SCENARIO 2

**Turning on RX Function Switch 9** will make the output relay de-energize if there is a system failure (closing N.C. to COM.).

### LOAD SHARING

Different delay times on the receivers can help with large electrical current pulls in the same field on start up.

## ENGINE PUMP WIRING

**HOT SHOTS AT THE PUMP NEED TO BE TURNED ON BEFORE THE HOT SHOTS AT THE PIVOT. HOT SHOTS ONLY TRANSMIT FOR 1 MINUTE WHEN THE SENSOR IS ACTIVATED. IF THE HOT SHOT AT THE PUMP IS TURNED ON AFTER THE PIVOT HOT SHOT IT WILL NOT OPERATE CORRECTLY UNTIL THE PIVOT HOT SHOT IS SET TO TRANSMIT AGAIN.**

**DO NOT** mount a HOT SHOT unit to an engine or engine cover because strong vibrations can be harmful to the unit.

The diagrams below show how to control an engine driven well using a simple 117 or 518 Murphy kill switch. Supply power to the Hot Shot by hooking up the 12v positive input to the 12v positive terminal on the battery. Run a wire from the Negative input on the Hot Shot to the negative terminal on the battery or to a good ground connection. Install a jumper wire connecting the Hot Shot's negative terminal to the COM terminal. Connect a wire from the N.C. terminal on the Hot Shot to the S or the SW1 terminal on the Murphy kill switch.

### Using Engine Start Up Mode:

Turn on function switch 6 and turn on the power to the Hot Shot to enable the Engine Startup Mode (*for details see pg 3*). When activated the Supervision and Relay LED will come on and the ground going to the Murphy switch to allow the engine to start and stay running until the Hot Shot at the pivot has sent its relay ON command to the Hot Shot at the pump taking control of it and turning off the Supervision LED. If the pivot Hot Shot has not sent the relay ON command within 15 min of starting the Hot Shot at the pump, it will kill the engine and you will have to turn it off and then back on again to get it into Engine Startup Mode again. If the pivot stops or the safety is tripped it's Hot Shot will send an OFF command to the pump's Hot Shot that will close its COM to NC. This shorts the S terminal to ground and kills the engine. Other variations and Murphy Kill switches may work as well.

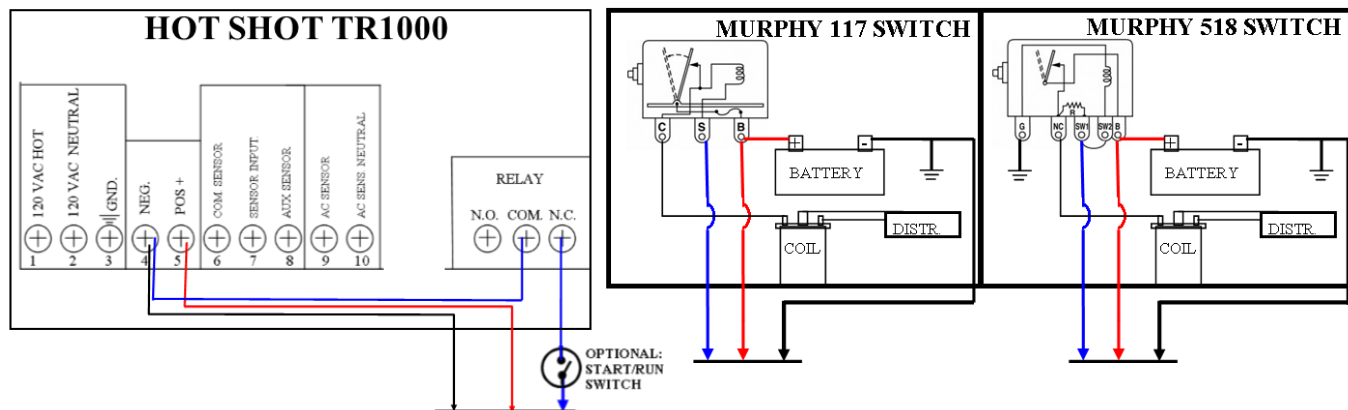

**PUMP START:** IF USING A START/RUN SWITCH FLIP IT TO START. POWER UP THE HOT SHOT AND START THE ENGINE AT THE PUMP. WHEN THE PIVOT IS PRESSURED UP IT'S HOT SHOT WILL TRANSMIT A RELAY ON COMMAND TO THE HOT SHOT AT THE PUMP. WHEN A RELAY ON COMMAND IS RECEIVED THE HOT SHOT WILL CLOSE ITS N.O. TO COM CONTACTS AND LIGHT UP THE RELAY LED. THIS WILL REMOVE THE GROUND FROM THE MURPHY ALLOWING THE ENGINE TO STAY RUNNING. IF USING A START/RUN SWITCH FLIP IT TO RUN.

**PUMP STOP:** WHEN THE HOT SHOT AT THE PIVOT'S SENSOR INPUT TO SENSOR COM IS OPENED IT SENDS OUT THE RELAY OFF COMMAND TO THE HOT SHOT AT THE PUMP. WHEN A RELAY OFF COMMAND IS RECEIVED THE HOT SHOT WILL OPEN ITS N.O. TO COM CONTACTS AND TURN OFF THE RELAY LED. THIS WILL NOW SUPPLY A GROUND TO THE MURPHY STOPPING THE ENGINE.

## ELECTRIC PUMP WIRING

**CAUTION:** Never switch any voltage greater than 120v with the Hot Shot's internal relays. This will ruin the relay and void all manufacturer warranties. Use an externally mounted 120v coil relay to switch all voltages greater than 120v. See diagram below.

**HOT SHOTS AT THE PUMP NEED TO BE TURNED ON BEFORE THE HOT SHOTS AT THE PIVOT ARE TURNED ON. HOT SHOTS ONLY TRANSMITT FOR 1 MINUTE. IF THE HOT SHOT AT THE PUMP IS TURNED ON AFTER THE ONE AT THE PIVOT IT WILL NOT OPERATE CORRECTLY UNTIL THE HOT SHOT AT THE PIVOT IS SET TO TRANSMITT AGAIN.**

To supply power to the Hot Shot mount a 480v-120v step-down transformer in the pump panel. A Hot Shot only requires 1 watt of power to operate. *Hot Shot Systems suggest using a minimum of a single phase 60 hertz 0.050kVA transformer. They are available for purchase through Hot Shot Systems, just request when ordering.* Mount a 3 terminal fuse block and a 120vac relay in the pump panel. *Hot Shot Systems suggest using a 115V AC coil relay.* Wire two, 480v conductors through the first two fuses (2 amp each) to the primary side of the step-down transformer. Wire the 120v X2 terminal of the step-down transformer through the remaining fuse (2 amp) and then to terminal #1 (120vac hot input of the Hot Shot). Wire the 120v X1 terminal of the step-down transformer to the terminal #2 (120vac neutral input of the Hot Shot). Terminals may be different according to the transformer installed. Add a jumper from terminal #1 of the Hot Shot to it's COM terminal. Wire the NO terminal on the Hot Shot to one side of the 120v relay's coil. Connect the other side of the relay's coil to the X1 terminal of the step-down transformer. Connect a wire from the ground terminal of the Hot Shot to a central grounding system or an NEC approved ground rod.

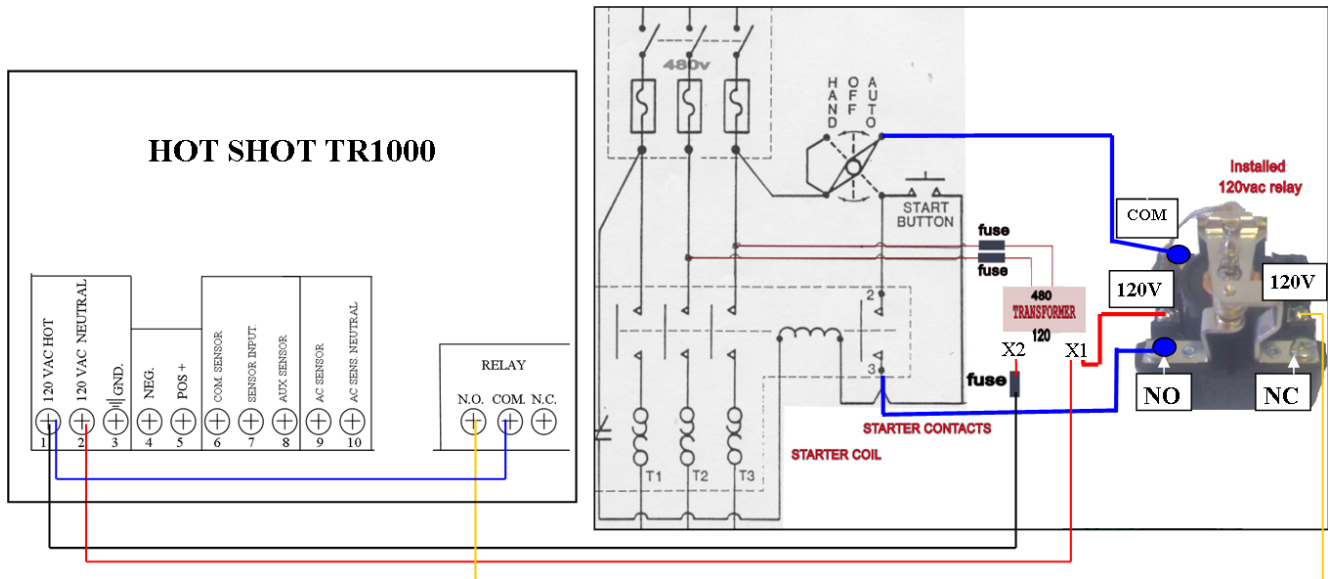

**PUMP START:** WHEN THE HOT SHOT AT THE PIVOT'S SENSOR INPUT TO SENOR COM IS CLOSED IT SENDS OUT THE RELAY ON COMMAND TO THE HOT SHOT AT THE PUMP. WHEN A RELAY ON COMMAND IS RECEIVED THE HOT SHOT WILL CLOSE ITS N.O. TO COM CONTACTS AND LIGHT UP THE RELAY LED. THIS WILL ENERGIZE THE 120VAC RELAY TO CLOSE THE 480V PUMP CONTACTOR STATRRTING THE PUMP.

**PUMP STOP:** WHEN THE HOT SHOT AT THE PIVOT'S SENSOR INPUT TO SENOR COM IS OPENED IT SENDS OUT THE RELAY OFF COMMAND TO THE HOT SHOT AT THE PUMP. WHEN A RELAY OFF COMMAND IS RECEIVED THE HOT SHOT WILL OPEN ITS N.O. TO COM CONTACTS AND TURN OFF THE RELAY LED. THIS WILL DE-ENERGIZE THE 120VAC RELAY TO OPEN THE 480V PUMP CONTACTOR STOPING THE PUMP.

## APPENDIX

### SUPERVISION FEATURE

The Supervision Feature is a great way for checking at a glance the integrity of communications between the transmitter and receivers. The supervision feature is designed to work with only one transmitter per system as the supervision feature's timer can operate on multiple receivers at the same time. When function 9 (Refresh) is turned on in the transmitter, it will send out a check-in signal (*technically it's a command telling each receiver on the system to reset it's supervision timer, i.e. system is working properly*) every 45 minutes. If the check-in signal is not heard by the receiver before the internal supervision timer expires, due to transmitter or receiver issues, the receiver will then look at its function switches (7, 8 or 9) and take the selected course of supervision action. See below.

#### Receiver's Supervision/Fail Safe action:

If [Function 8](#) is on in the receiver and the supervision timer does not get reset by the transmitter's check-in signal the supervision LED will begin to blink continuously. No action will be performed by the receivers relay. The supervision LED will continue to blink until either the receiver receives the transmitter's check-in signal or the receiver is reset by pressing the reset button, if equipped, or by cycling the power to the receiver.

If [Function 7](#) (Fail Safe Scenario 1) is on in the receiver and the supervision timer does not get reset by the transmitter's check-in signal the supervision LED will begin to blink continuously. This will also activate the receivers relay which will close or open your contacts, (*N.C. / N.O.*) possibly triggering an alarm, call out system, deactivate an external relays coil or trip a tattletale circuit to stop the device it is controlling. The supervision LED will continue to blink and the receivers relay will stay activated until either the receiver receives the transmitter's check-in signal, a relay reset command from the transmitter or the receiver is reset by pressing the reset button, if equipped, or by cycling or losing power to the receiver.

**Operational Note:** When using Fail Safe Scenario 1, the receiver's relay is energized and if power is lost while the receiver is in Fail Safe operation, the receiver's relay will de-energize. When power is restored, the receivers relay will not immediately go back into Fail Safe operation. The receivers relay will remain de-energized and the device it is controlling may restart. The receiver will not go into Fail Safe operation again until it's supervision timer has expired again. If this situation occurs, a tattletale device that does not recycle when the power comes back on, should be installed to hold the circuit as needed for your situation.

If [Function 9](#) (Fail Safe Scenario 2) is on in the receiver and the supervision timer does not get reset by the transmitter's check-in signal the supervision LED will begin to blink continuously. This will also deactivate the receiver's relay, if currently activated, which will close or open your contacts, (*N.C. / N.O.*) possibly triggering an alarm, call out system, deactivate any external relays coil or trip a tattletale circuit to stop the device it is controlling. The supervision LED will continue to blink until either the receiver receives the transmitter's check-in signal or a relay ON or OFF command from the transmitter.

#### Transmitter Setting for Supervision/Fail Safe Operation at the Receiver:

[Function 9](#) (*Refresh - sends checking in signal every 45 min.*)

This function must be turned on in the transmitter so the transmitter will send out the signal to make the receiver(s) supervision timer reset. IF the transmitter does not have this function turned on the absence of the refresh/check in signal will cause the reciver(s) to go into Supervision or a Fail Safe action.

#### Testing Supervision/Fail Safe Operation:

A good way to test the Supervision/ Fail Safe Operation is to turn off function switch 9 on the transmitter, so it will no longer send the refresh/check-in signal. Once the receiver's supervision timer has expired, (*may take up to 3 hrs depending on the version of software the receiver is operating*) the Supervision LED will begin to blink and depending upon the Fail Safe scenario you have chosen, the receivers relay will activate or de-active.



# HOT SHOT GROUNDING FOR SAFETY AND PEAK PERFORMANCE

Hot Shot wireless systems are equipped with a GROUND terminal that needs to be connected to an NEC approved ground rod. A Hot Shot has various lightning and static protection devices incorporated on the circuit board that require proper grounding to operate. Any equipment or device panels operating with or near the Hot Shot should also be connected to the grounding system. A good ground will enhance the transmit and receive range of the Hot Shot System.

To watch a "How To" video on this feature click on the link below:

["PROPER GROUNDING"](#)

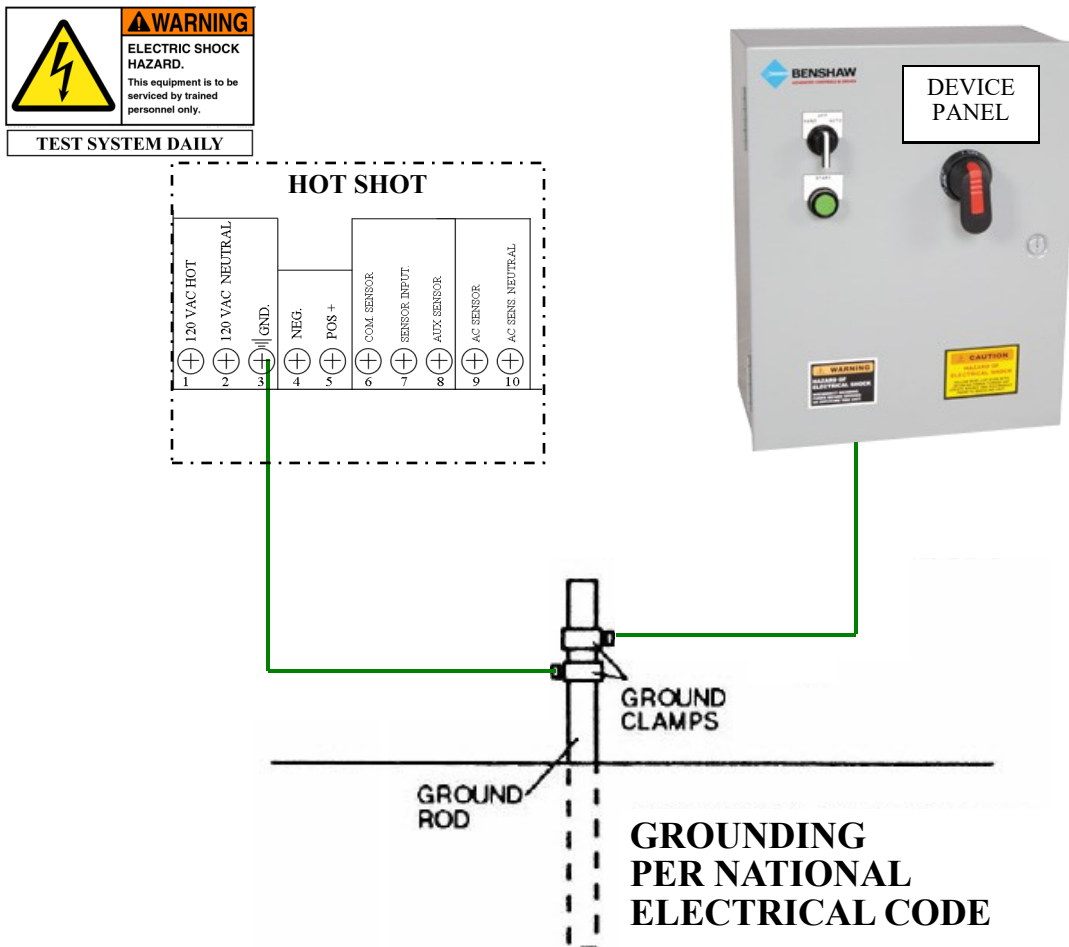

## Warranty

**The warranty below constitutes the only warranty in connection with any sale from Hot Shot Systems Inc. and is in lieu of all other warranties, express or implied, written or oral. THERE ARE NO IMPLIED WARRANTIES OF MERCHANT-ABILITY OR FITNESS FOR A PARTICULAR PURPOSE THAT APPLY TO ANY SALE FROM HOT SHOT SYSTEMS INC.**

Hot Shot Systems Inc., warrants to You that Products (Products meaning any item purchased from Hot Shot Systems) will be free from defects in materials and workmanship under normal use and service for one (1) year from the purchase date. A product issue under this Limited Warranty must be presented during the Limited Warranty period and within thirty (30) days after any covered condition has occurred. A claim under this Limited Warranty shall be satisfied by either, in Hot Shot Systems sole discretion, repairing or replacing the Product. Replacement Products may be new or reconditioned.

To make a claim under this Limited Warranty, Hot Shot Systems must first issue You a Returned Material Authorization (RMA) number. This number can be obtained by calling Hot Shot Systems and a RMA number will be provided over the phone. A copy of the RMA number must be included with any materials shipped to Hot Shot Systems. The entirety of Products must be sent back to Hot Shot Systems and properly packaged to ensure against damage during shipping. If Hot Shot Systems determines that the claim is covered by this Limited Warranty, Hot Shot Systems will either, in its sole discretion, repair or replace the Products and/or part. Any damages not covered under this Limited Warranty will not be repaired until a purchase order is received.

The Limited Warranty period shall not be extended by the replacement or repair of Products or parts under this Limited Warranty but the remaining Limited Warranty period shall continue in effect and be applicable to the replaced or repaired Products or parts under conditions of the Limited Warranty.

The term "Long Range Wireless Control" is not a guarantee of proper radio operation everywhere in all conditions. Radio operation is subject to transmission and receive limitations, customer equipment, weather, topography and other environmental and electrical considerations associated with radio technology also affect radio operation and radio operation may vary significantly within buildings. The radio operation range of Products is not guaranteed, and Hot Shot Systems cannot and does not guarantee or represent that the radio operation will operate correctly in all conditions. It is Your responsibility to determine daily if radio operation is operating correctly and to monitor the Products to determine the communication between Products. You should contact Hot Shot Systems for assistance if needed. As such, Hot Shot Systems is not liable for any causes of action, pollution, incurred costs, losses of any kind or damages of any kind whatsoever arising out of mistakes, omissions, interruptions, errors, customer equipment or defects in the radio operation and or Products.

Intended Use. Products are intended for non pollutant, non hazardous and non critical use only. Products are to be used and installed per the installation guide and any other instructions provided by Hot Shot Systems (collectively, the "Seller's Guidelines"). Any use beyond the intended non pollutant, non-hazardous and non critical use or against the Seller's Guidelines ("Unintended use") are at the End-User's own risk, and Hot Shot Systems does not warrant or make any representations whatsoever regarding the use of Products for any unintended use. Hot Shot Systems' Products are convenience items and are not intended to be a substitute for normal maintenance, monitoring, control and proper upkeep of equipment or property that Products are monitoring or controlling. Hot Shot Systems' Products are convenience items and are not intended to monitor equipment, control equipment, liquids, chemicals or other items which are pollutants, vital, hazardous, necessary, and/or have life-or-death consequences. The End-User should take care to determine prior to use whether Products are suitable, adequate or safe for the use intended. Since individual applications are subject to great variation, Hot Shot Systems makes no representation or warranty as to suitability or fitness of Products for any specific application.

Upon expiration of the Limited Warranty period, all liability of Hot Shot Systems shall be terminated. This Limited Warranty will also be terminated immediate due to any of the following cases: failure to follow installation and operating instructions, misuse or "Unintended use", alteration, abuse, accident or tampering, and repair by anyone other than Hot Shot Systems.

**THIS LIMITED WARRANTY IS EXCLUSIVE AND EXPRESSLY IN LIEU OF ALL OTHER WARRANTIES, OBLIGATIONS OR LIABILITIES, WHETHER WRITTEN, ORAL, EXPRESS OR IMPLIED, INCLUDING ANY WARRANTY OF MERCHANT-ABILITY OR FITNESS FOR A PARTICULAR PURPOSE, OR OTHERWISE. IN NO CASE SHALL HOT SHOT SYSTEMS BE LIABLE TO ANYONE FOR ANY CONSEQUENTIAL OR INCIDENTAL DAMAGES FOR BREACH OF THIS WARRANTY OR ANY OTHER WARRANTIES WHATSOEVER. This Limited Warranty gives specific legal rights.**

No employee, agent, dealer or other person is authorized to give any warranties on behalf of Hot Shot Systems Inc., nor to assume for it any other liability in connection with any of its products, except an officer of Hot Shot Systems Inc., in a signed writing.

### LIABILITY

Hot Shot Systems Inc. and its directors, officers, employees, subsidiaries and affiliates shall not be liable for pollution, pollution clean up, personal injury, property damage, hazardous conditions created, fluid spill cleanup, loss of product, loss of profit, or any other loss or expenses based on a claim the product(s) failed to operate properly. Test product daily to see if any malfunctions are present. If using this product in a situation where it is extremely critical to control your device to prevent damage of any kind, you must also use a call out system to notify a person in control of this situation. If this warranty and statement of liability is unacceptable, then do not purchase these products.

Hot Shot Systems makes no representation that Products and Services will reduce any risk of property loss, product loss, loss of profit, pollution or personal injury or prolong the life of any equipment or other property; or that Products and Services will in all cases provide adequate warning and protection. You understand that Products if properly installed and maintained may only reduce the risk of property loss or other loss but Products and Services are not an insurance or a guarantee that there will be no property loss, product loss, loss of profit, pollution or personal injury or other loss as a result. **CONSEQUENTLY, HOT SHOT SYSTEMS SHALL HAVE NO LIABILITY FOR ANY POLLUTION, PRODUCT LOSS, LOSS OF PROFIT, PROPERTY DAMAGE, PERSONAL INJURY OR OTHER LOSS OR EXPENSES INCURRED BASED ON A CLAIM THE PRODUCTS AND SERVICES FAILED TO GIVE WARNING.**

**NOTE:** This equipment has been tested and found to comply with the limits for a Class B digital device, pursuant to part 15 of the FCC Rules. These limits are designed to provide reasonable protection against harmful interference in a residential installation. This equipment generates, uses and can radiate radio frequency energy and, if not installed and used in accordance with the instructions, may cause harmful interference to radio communications. However, there is no guarantee that interference will not occur in a particular installation. If this equipment does cause harmful interference to radio or television reception, which can be determined by turning the equipment off and on, the user is encouraged to try to correct the interference by one or more of the following measures:

- Reorient or relocate the receiving antenna.
- Increase the separation between the equipment and receiver.
- Connect the equipment into an outlet on a circuit different from that to which the receiver is connected.
- Consult the dealer or an experienced radio/TV technician for help.

**15.21 INFORMATION to USER:**

The users manual or instruction manual for an intentional or unintentional radiator shall caution the user that changes or modifications not expressly approved by the party responsible for compliance could void the user's authority to operate the equipment.

FCC License is not required. This device operates on frequencies authorized for use in the Multi-Use Radio Service (MURS). MURS frequencies are available for unlicensed business or personal use. Any changes or modifications may void the user's authority granted by the FCC to operate this radio and should not be made. Use of this radio outside the country where it was intended to be distributed is subject to government regulations and may be prohibited.